

# O'Clear®

Innovation  
of the year

## The best concept for water disinfection

BIO-UV Group, specialist in ultraviolet water treatment for 20 years, offers you its brand new concept of water treatment combining the 2 best technologies on the market: UV and electrolysis.

### Principle

The O'Clear® UV treatment guarantees high-performance disinfection with every pass.

Remanence in the pool is ensured thanks to specific electrodes designed to work with the O'Clear® UV treatment and only 0.5 g/litre of salt.

The disinfection system is controlled by filtration.

The result: perfectly pure, clean water.

### Advantages

- Perfectly disinfected (UV) and disinfecting water (salt at only 0.5 g/litre)
- Just one bag of salt is enough (instead of 7 to 10 with conventional electrolysis)\*
- Fully automatic Plug & Play system
- Easy to install and use
- Requires very little cleaning and maintenance
- Perfectly safe for swimmers
- Comfort and softness of clean, crystal-clear water
- No risk of allergy
- No chlorine smell, no taste of salt
- Reduced risk of corrosion
- Compatible with all pool types\*\*, including pools with covers
- Guaranteed treatment reliability and efficiency



### The UV principle

At a wavelength of 254 nanometres, UV light eradicates any micro-organisms present in the water (viruses, bacteria, algae, moulds, etc.).

It poses absolutely no risk to human health. Water is disinfected as it passes through the treatment cycle; it all happens inside the unit where the natural UV phenomenon is reproduced.

\*For a 50 m<sup>3</sup> swimming pool    \*\*Excluding the stainless steel pool

BIO-UV  
Group

# O'Clear®

Model	Max. flow rate	High Performance UV Lamp	Input/Output Diameter	Height of reactor	Diameter of reactor	Sizes of electrical boxes	Max. volume of pool
O'Clear 25	25 m <sup>3</sup> /h	1 x 87 W	75 mm (75/63 mm and 75/50 mm reductions provided)	1091 mm	200 mm	L 270 x H 273 x D 103 mm	100 m <sup>3</sup>
O'Clear 15	15 m <sup>3</sup> /h	1 x 55 W	75 mm (75/63 mm and 75/50 mm reductions provided)	845 mm	200 mm	L 270 x H 273 x D 103 mm	50m <sup>3</sup>

## Technical characteristics

- PVC reactor
- **Very long lamp life** (13,000 hours depending on number of switch-ons)
- **Adjustment of the operating time of the electrolyser, triggered at the end of the filtration period**
- **Reverse polarity on electrodes, adjustable according to water quality**
- **Dedicated electronic ballast for maximum UV lamp output and integrated control**
- **UV lamp function check by indicator light including hour meter, lamp failure alarm, lamp replacement alert**
- **Input/output connection by supplied union fittings**
- **Flow sensor included**
- **Exists with or without O'Clear pH control®**

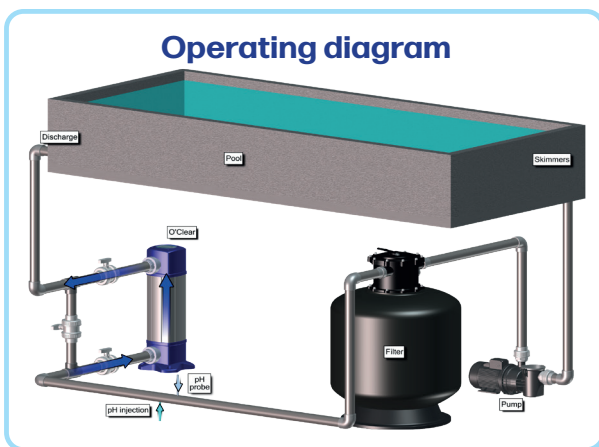
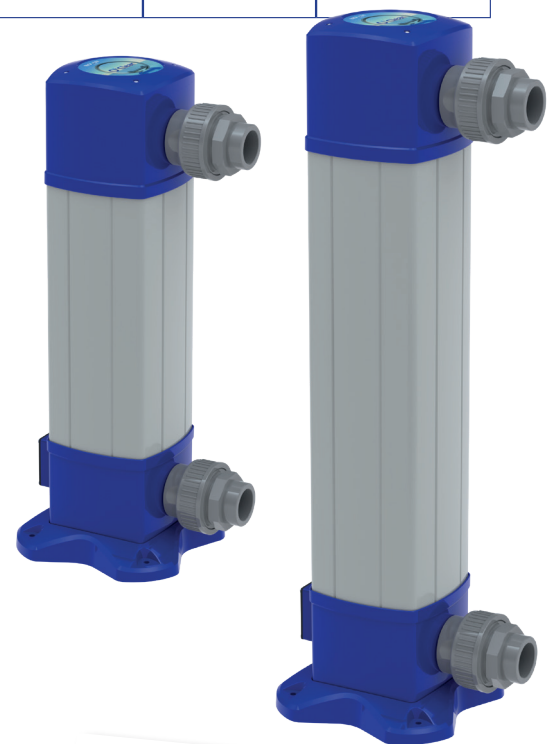

## Contact us

export@bio-uv.com

+33(0)4 99 133 911

BIO-UV Group, 850 avenue Louis Médard, 34400 Lunel

[www.bio-uv.com](http://www.bio-uv.com)

